

सत्यमेव जयते

TEST CERTIFICATE

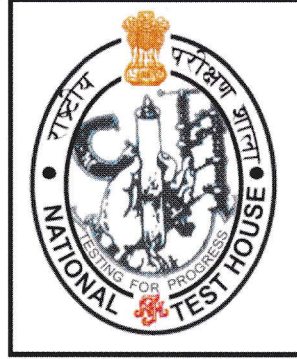

भारत सरकार

उपभोक्ता मामले, खाद्य एवं सार्वजनिक वितरण मंत्रालय

Government Of India

Ministry Of Consumer Affairs , Food and Public Distribution

राष्ट्रीय परीक्षण शाला (पूर्वी क्षेत्र)

National Test House

11/1, जजेस कोर्ट रोड, अलीपुर, कोलकाता-700 027.

11/1 , Judges' Court Road , Alipur , Kolkata - 700 027.

Phone No : 91-33-2479-3510/2449-8027/2479-1534 , Fax : 91-33-2449-8026

email: nthcal@wb.nic.in

ध्यान दें:

1. यह परीक्षण प्रमाण पत्र पूर्ण रूप के अलावा तब तक पुनः प्रस्तुत नहीं किया जाएगा जब तक कि अनुमोदित सारांश प्रस्तुति के लिए निदेशक, राष्ट्रीय परीक्षण शाला (पू.क्षे.), कोलकाता से अनुमति न लिया गया हो।
2. यह परीक्षण प्रमाण पत्र केवल उन नमूनों/सामग्रियों से संबंधित है जो कि प्रयोगशाला में परीक्षण के लिए जमा किया गया हो।

Note :

1. This Test Certificate shall not be reproduced except in full, unless permission for the reproduction of an approved abstract has been obtained from the Director, National Test House (E.R.), Kolkata.
2. This Test Certificate relates only to samples/items submitted to the laboratory for test.



सत्यमेव जयते

भारत सरकार
Government of India

राष्ट्रीय परीक्षण शाला (पूर्वी क्षेत्र)
National Test House (Eastern Region)

11/1, जजेस कोर्ट रोड, अलीपुर, कोलकाता - 700 027
11/1, Judges' Court Road, Alipore, Kolkata - 700 027



परीक्षण प्रमाण पत्र

TEST CERTIFICATE

INTERIM/FINAL REPORT

Number of Copies issued Single

परीक्षण प्रमाण पत्र सं.
Test Certificate Noजारी होने की तिथि
Date of Issueकोड नं
Code Noपृष्ठ
Pageपृष्ठों की संख्या
No of Pages

NTH(ER)/EL(A)/2022/003

06/01/2022

1641205922524

1

2

जिसे जारी करना है

CONTROLBLUE AUTOMATION & SOFTWARE (I) PVT. LTD.

Issued To

पता

GE-125, Rajdanga Main Road, Kasba, Kolkata-700107.

Address

ग्राहक का संदर्भ सं एवं दिनांक

Email

Date: 27/12/2021

Customer's Ref. No.

पंजिका सं एवं दिनांक

003/NTH(ER)/EL(A)/04/01/2022

Register No & Date

परीक्षण सामग्री का विवरण

One sample stated to be Enclosure for IP-54
test, Make: ControlBlue Automation & Software (I) Pvt. Ltd.

Description of Test Item

परीक्षण सामग्री का पहचान

Marking: As in attached sheet "Annexure".

Identification of Test Item

नमूना का विशिष्टि (यदि हों)

Not Applicable.

Product Specification (If any)

नमूना प्राप्ति की तिथि

03/01/2022

Date of Receipt of the Test Item

कार्य सम्पादन की तिथि

From: 04/01/2022

To: 04/01/2022

Date(s) of Performance of Tests

व्यावहृत प्रणाली का पहचान

Drawing Verification as per Customer Requirement.

Method(s) used for Test

Not Applicable.

नमूना प्रक्रिया जहाँ प्रासंगिक हों

Sampling Procedure where relevant

Tested By

Checked By

Approved By

Sayantan Das
SO ElectricalArvind Singh Negi
Scientist- B (Electrical)Biswa Ranjan Mandal
Scientist- C (Electrical)



सत्यमेव जयते

भारत सरकार
Government of India

राष्ट्रीय परीक्षण शाला (पूर्वी क्षेत्र)
National Test House (Eastern Region)

11/1, जज्जस कोर्ट रोड, अलीपुर, कोलकाता - 700 027
11/1, Judges' Court Road, Alipore, Kolkata - 700 027



परीक्षण प्रमाण पत्र

TEST CERTIFICATE

INTERIM/FINAL REPORT

Number of Copies issued Single

परीक्षण प्रमाण पत्र सं.

Test Certificate No

NTH(ER)/EL(A)/2022/003

जारी होने की तिथि

Date of Issue

06/01/2022

कोड नं

Code No

1641205922524

पृष्ठ

Page

2

पृष्ठों की संख्या

No of Pages

2

Sl. No.

Test Name

Test Result

Limit

1

Drawing Verification

As In attached sheet "Annexure".

As In attached sheet
"Annexure".

टिप्पणी

Note

Drawing No. CBASIPL/IP TEST/COL/20 is a part of this test certificate.

: Comments have been offered against individual tests.

केफियत

Remarks

Tested By

Sayantan Das

SO Electrical

Checked By

Arvind Singh Negi

Scientist- B (Electrical)

Approved By

Biswa Ranjan Mandal

Scientist- C (Electrical)



सत्यमेव जयते

भारत सरकार
Government of India

राष्ट्रीय परीक्षण शाला (पूर्वी क्षेत्र)
National Test House (Eastern Region)

11/1, जजेस कोर्ट रोड, अलीपुर, कोलकाता - 700 027
11/1, Judges' Court Road, Alipore, Kolkata - 700 027



TEST CERTIFICATE

Test certificate no
NTH(ER)/EL(A)/2022/003

Date of Issue
05/01/2022

Code No
1641205922524

Page 1 No. of Pages 1

"Annexure"

1. **Marking:** The following marking were provided on the sample:-

blue
automation
ControlBlue Automation & Software (I) Pvt. Ltd.
Kolkata

2. **Test Result :**

| Sl. No. | Test Details | Requirements | Test Result | Remarks |
|---------|---|--|--|--------------|
| 1 | Drawing Verification [Carried out as per customer requirement] | Verification of Drawing no. CBASIP/ IP TEST/KOL/20 | Dimensions measured in mm are indicated in blue ink on the drawing no. CBASIP/ IP TEST/KOL/20, supplied by the firm. | Satisfactory |

Tested By

Sayantan Das
SO (Electrical)

Checked By

Arvind Singh Negi
Scientist-B (Electrical)

Approved By

Biswa Ranjan Mandal
Scientist-C (Electrical)

File No. : NTH (ER)/EL(A)/2022/003

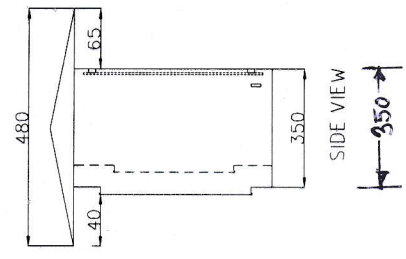
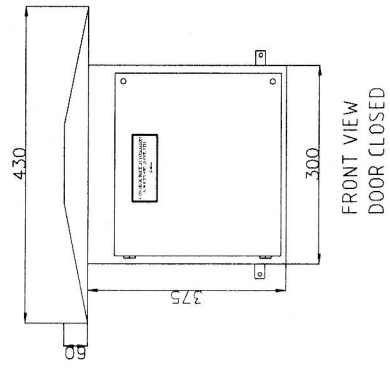
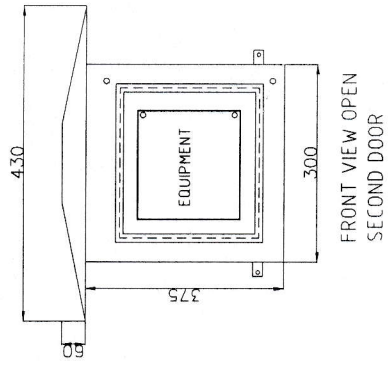
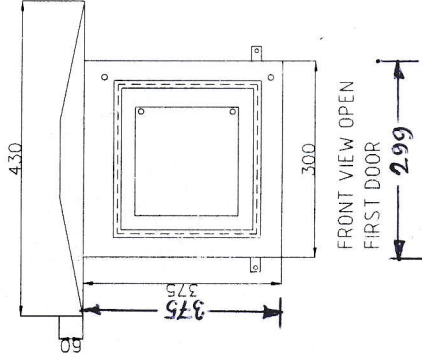
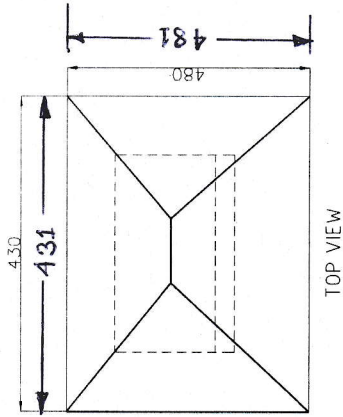

* Drawing verified w.r.t. dimensions only

GENERAL NOTES:
 1) ALL DIMENSIONS ARE IN MM.
 2) DIMENSION TOLERANCE +2%

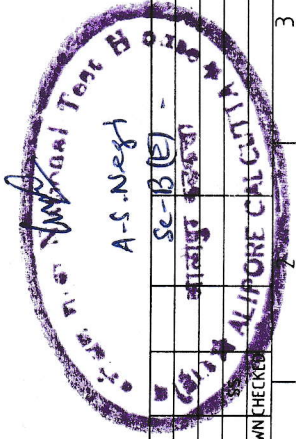

CONTROL BLUE AUTOMATION & SOFTWARE (P) PVT. LTD.
 ADDRESS: GE-171, RAJDANGA MAIN ROAD,
 KOLKATA-700107
 PHONE-033-24413339

CBAT
 CONTROL BLUE AUTOMATION & SOFTWARE (P) PVT. LTD.

| | | | | | | | |
|----------|----------|---------------|--|---------------------|------------------|---|---|
| REV | DATE | DRAWN/CHECKED | DRG. NO | CBAS/JP TEST/KOL/20 | 6 | 7 | 8 |
| 00 | 15/01/20 | SJ | | | | | |
| PROJECT: | | | IP TYPE TEST AT NATIONAL TEST HOUSE, LIPORE, KOLKATA | | SHEET NO. 1 | | |
| PROJECT: | | | N.T.S | | TOTAL SHEET OF 1 | | |

S.Das, Self

NTH

A Journey towards Century
(Estd. 1912)

NATIONAL TEST HOUSE

Government of India

Website: <http://www.nth.gov.in>

CONTACT US

Laboratories

▶ **Director,**
National Test House(ER),
Block- CP, Sector-V,
Salt Lake, Kolkata- 700091.
Tel: 91 - 33 - 2367 3871/9741/3308
91- 33 - 2367 3429/30/31(EPBX)
Tel / Fax: 91-33 - 2367 3871/3308
e-mail : nthcal@wb.nic.in

▶ **Scientist-In-Charge,**
National Test House(ER),
11/1, Judges' Court Road, Alipore,
Kolkata- 700027.
Tel: 91-33 - 2479 3510, 2449 8027, 2479 1534
Fax: 91-33 - 2449 8026
e-mail : nthcal@wb.nic.in

▶ **Director,**
National Test House(WR),
Plot No.F-10, MIDC, Marol,
Andheri (E), Mumbai - 400 093.
Tel: 91-22 - 2834 1483, 2835 2350, 2835 2341
Fax: 91-22 - 2834 1767
e-mail: nthwr@mtnl.net.in

▶ **Director,**
National Test House(SR),
Tharamani, Chennai- 600113.
Tel: 91- 44 - 2243 2374/2243 1157
Fax: 91- 44 - 2243 3158
e-mail: nthsr@tn.nic.in/ nthsr@dataone.in

▶ **Director,**
National Test House(NR),
Kamla Nehru Nagar, Ghaziabad- 201002.
Tel: 91-120 - 2789 906/813/493
Fax: 91-120 - 2789 883
e-mail: nthnr@vsnl.net

▶ **Scientist-In-Charge,**
National Test House(NWR),
Road No. 9F1 , Plot No.E-763 ,
VK Industrial Area, Jaipur- 302013.
Tel: 91-141- 2174 979/2175 318
Tel / Fax: 91-141 - 2330 074
e-mail: nthjaipur@dataone.in

▶ **Scientist-In-Charge,**
National Test House(NER),
Kalapahar, CITI Complex, Guwahati- 781 016.
Tel: 91-361 - 247 7405/2471938
Tel / Fax: 91-361 - 247 1938
e-mail: nthner@assam.nic.in

Headquarters

Director General,
National Test House,
Block- CP, Sector-V, Salt Lake, Kolkata- 700091.
Tel: 91- 33 - 2367 3870/3872/3869
Fax: 91- 33 - 2367 3868/3869
e-mail: dgnth@wb.nic.in

Your valued feedback will help us to improve